



THE POWER OF **CONNECTED**

CK75

powered by Android™ 6.0

Quick Start Guide

Out of Box

Make sure that your shipping box contains these items:

- CK75 mobile computer (Model CK75LAN)
- Rechargeable 3.7 V, Lithium-ion battery
- Product Documentation

If you ordered accessories for your mobile computer, verify that they are also included with the order. Be sure to keep the original packaging in case you need to return the mobile computer for service.

Memory Card Specifications

Honeywell recommends the use of Single Level Cell (SLC) industrial grade microSD™ memory cards with the computer for maximum performance and durability. Contact a Honeywell sales representative for additional information on qualified memory card options.

Computer Features

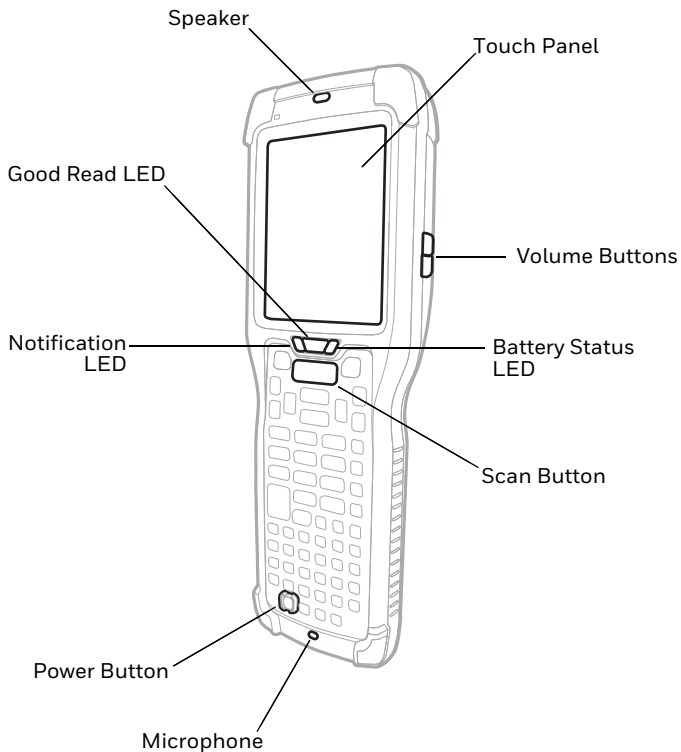

Note: Hand strap not shown.

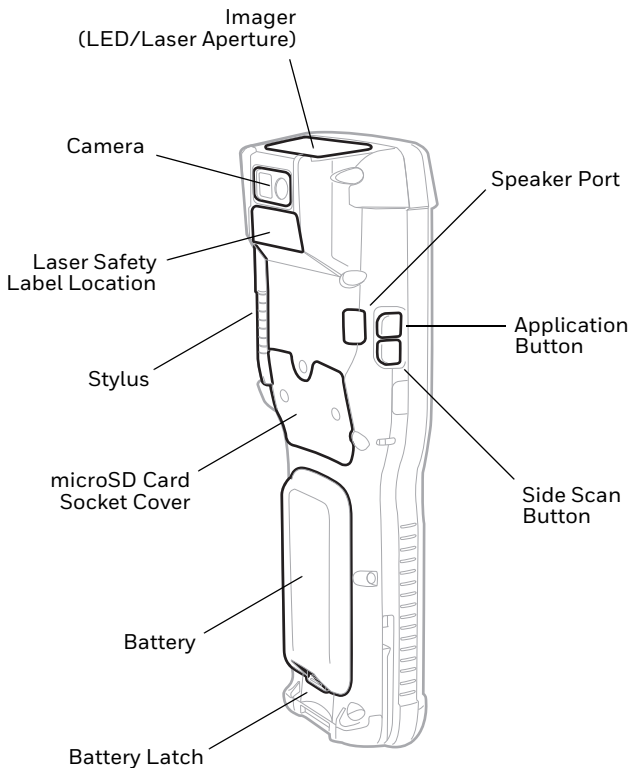

Detach Hand Strap

Detach the hand strap to access to the back of the computer.

Note: Battery pack shown installed. To learn more, see “[Install the Battery](#)”.

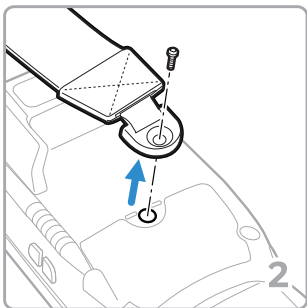
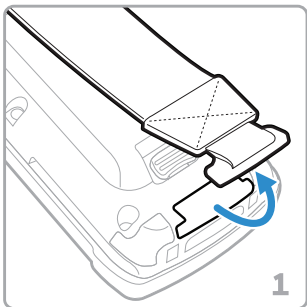

Install a microSD Card

Note: Format the microSD card before initial use.

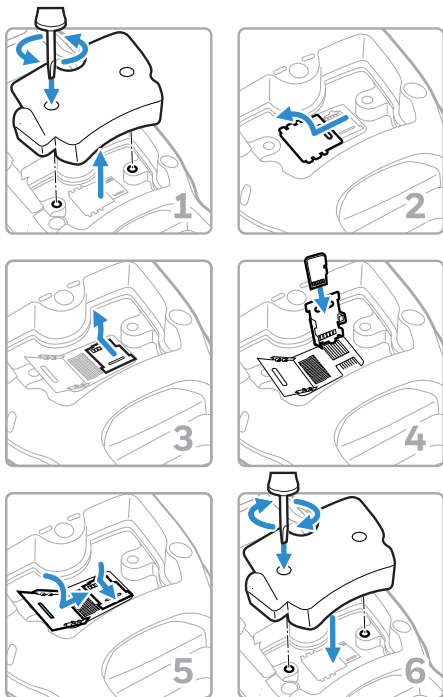

Note: Always power off the computer and remove the battery before attempting to install or remove a card.

Install the Battery

The CK75 mobile computer ships with a Lithium-ion 3.7 V, 5200 mAH (19.24 Wh) battery manufactured for Honeywell International Inc.



We recommend use of Honeywell Li-ion battery packs. Use of any non-Honeywell battery may result in damage not covered by the warranty.

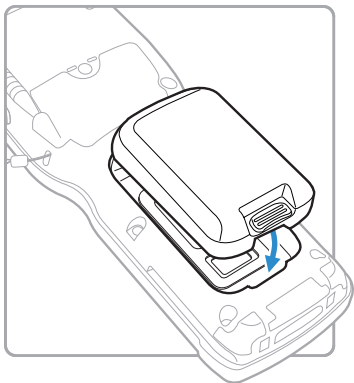

Ensure all components are dry prior to placing the battery in the computer. Mating wet components may cause damage not covered by the warranty.

Charge the Computer

The CK75 mobile computer ships with a partially charged battery. Charge the battery with a 70 Series charging device for a minimum of **6 hours**.

Using the computer while charging the battery increases the time required to reach a full charge. If the CK75 is drawing more current than supplied by the charging source, charging will not take place. For additional information, see the user guide.



We recommend the use of Honeywell peripherals, power cables and power adapters. Use of any non-Honeywell accessories or power adapters may cause damage not covered by the warranty.

CK75 mobile computers are designed for use with the following charging accessories: DX1 Desktop Dock, DX2 Dual Dock, and DX4 Quad Dock and a power supply.



Ensure all components are dry prior to mating the computers and batteries with peripheral devices. Mating wet components may cause damage not covered by the warranty.

Turn Power On/Off

The computer automatically turns on when you install the battery pack.

Note: *You should always place the computer in Battery Swap mode for a quick battery change. If you are removing the battery for a longer period, always power off the computer.*

To turn the computer off:

1. Press and hold the **Power** button until the options menu appears.
2. Touch **Power Off**.
3. When prompted to shut down the phone, touch **OK**.

Note: *To turn the computer back on, press and release the Power button.*

Sleep Mode

Sleep mode automatically turns the touch panel display off and locks the computer to save battery power when the computer is inactive for a programmed period of time.

1. Press and release the Power button to wake the computer.
2. Drag the lock  toward the top of the display to unlock the computer.



Note: *To adjust the time out limit, touch **All Apps > Settings > Display > Sleep**.*

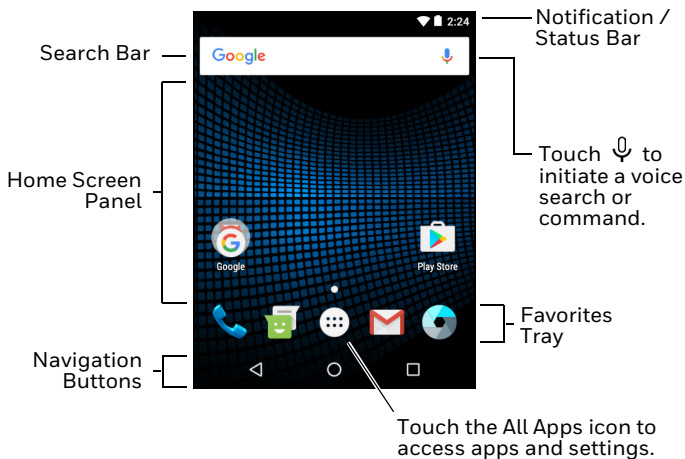



About the Home Screen



To learn how to customize the Home screen, see the user guide.

Navigation and Function Buttons

Buttons	Description	Function
	Back	Return to the previous screen.
	Recent Apps	View and switch between recently used apps.
	Home	Return to Home screen.

Buttons	Description	Function
	Scan	Trigger the scanner.
	Up, Down, Left and Right	Move up, down, right or left on the screen.
	Modifiers	Press a modifier key before pressing another key to access an alternate key value or function. Alternate key values appear on the keypad overlay near the relevant key. Modifier key shape and availability depend on keypad model types.
	Volume	Raise (top button) or lower (bottom button) the volume of the speaker.
	App and Scan	Press the application button (top) to open the Notes app and the scan button (bottom) to trigger the scanner.

To learn more about how to use the keypad for your computer model, see the user guide.

Scan a Bar Code

Note: For optimum performance, avoid reflections by scanning the bar code at a slight angle.

1. Point the computer at the bar code.
2. Touch and hold the **Scan** button.
3. Center the aiming beam over the bar code.
When the scanner successfully reads the bar code, the computer beeps, and the Good Read LED turns on briefly. The bar code information is entered into the application in use.
4. Release the **Scan** button.

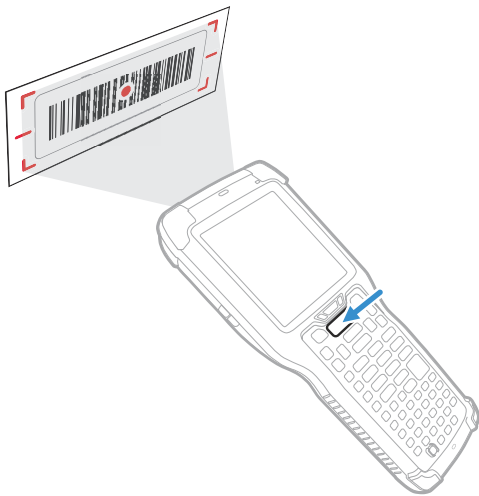

Sync Data

To move files between your CK75 and a computer:

1. Connect the CK75 to your computer using a USB charge/communication accessory.
2. By default, the CK75 is in USB charging only mode. To enable file transfers, swipe down from the top of the Home screen to access the Notifications panel.
3. Touch the USB notification, and then select either **File transfers (MTP)** or **Photo transfer (PTP)**.
4. Depending on the Windows® operating system, either open **File Explorer** or **Windows Explorer**.
5. Under “Computer” or “This PC”, click on the CK75. You can now copy, delete and/or move files or folders between the computer and CK75 or a microSD card installed in the CK75 as you would with any other storage drive (e.g., cut and paste or drag and drop).

Restart the Computer

You may need to restart the mobile computer to correct conditions where an application stops responding to the system or the computer seems to be locked up.

1. Press and hold the **Power** button until the options menu appears.
2. Select **Reset** and then **OK**.

To restart the computer if the touch panel display is unresponsive:

- Press and hold the **Power** button for approximately 8 seconds until the computer restarts.

Note: *If you try to restart the computer and still experience issues, you may need to see the user guide for information on how to perform a Factory Reset (Clean Boot).*

Use Battery Swap Mode for Battery Replacement

You should always place the computer in Battery Swap mode before removing the battery. Battery Swap mode places the computer in a low power state so that the battery can be removed for a short period of time.

To activate Battery Swap mode:

1. Press and hold the **Power** button until the options menu appears.
2. Touch **Battery Swap**.
3. After replacing the battery, press and release the **Power** button to wake the device.

Support

To search our knowledge base for a solution or log into the Technical Support portal and report a problem, go to www.hsmcontactsupport.com.

User Documentation

For the user guide and other documentation, go to www.honeywellaidc.com.

Limited Warranty

For warranty information, go to www.honeywellaidc.com and click **Get Resources > Product Warranty**.

Patents

For patent information, see www.hsmpats.com.

Trademarks

Google Play, Google and Android are trademarks of Google Inc.

Windows, File Explorer, and Windows Explorer are either registered trademarks or registered trademarks of Microsoft Corporation in the United States and/or other countries.

Disclaimer

Honeywell International Inc. (“HII”) reserves the right to make changes in specifications and other information contained in this document without prior notice, and the reader should in all cases consult HII to determine whether any such changes have been made. The information in this publication does not represent a commitment on the part of HII.

HII shall not be liable for technical or editorial errors or omissions contained herein; nor for incidental or consequential damages resulting from the furnishing, performance, or use of this material. HII disclaims all responsibility for the selection and use of software and/or hardware to achieve intended results.

This document contains proprietary information that is protected by copyright. All rights are reserved. No part of this document may be photocopied, reproduced, or translated into another language without the prior written consent of HII.

Copyright © 2017 Honeywell International Inc. All rights reserved.